

NEUGART PLE for Direct Motor Attachment “DMA”

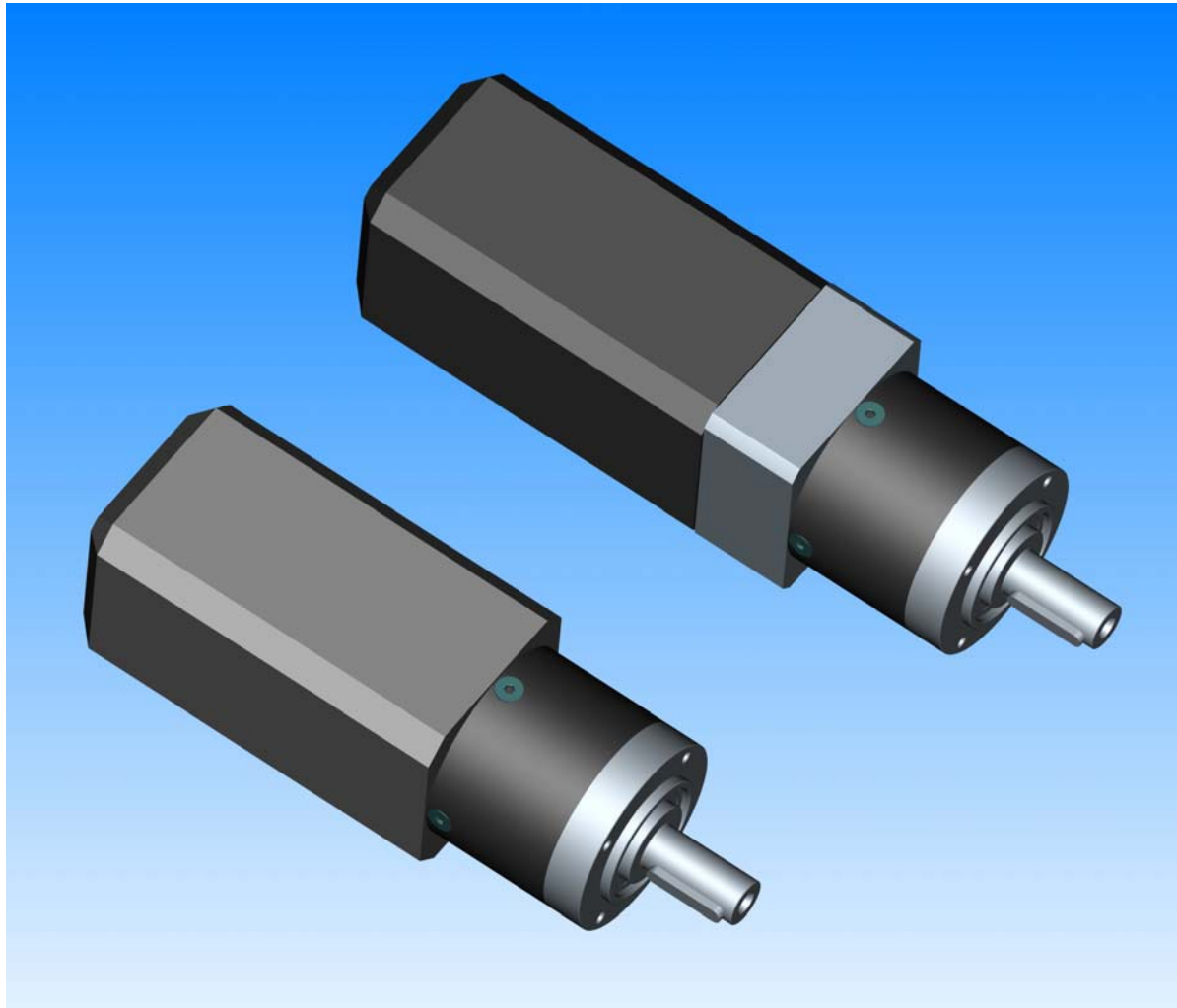

Advantages of DMA:

Compact Integrated
Space-saving Design

Increased Stiffness

Weight Reduction

Cost Reduction

Available for:

PLE 40, 60, 60/70, 80,
80/90

PLFE 64 and 90

NEUGART PLE for Direct Motor Attachment DMA

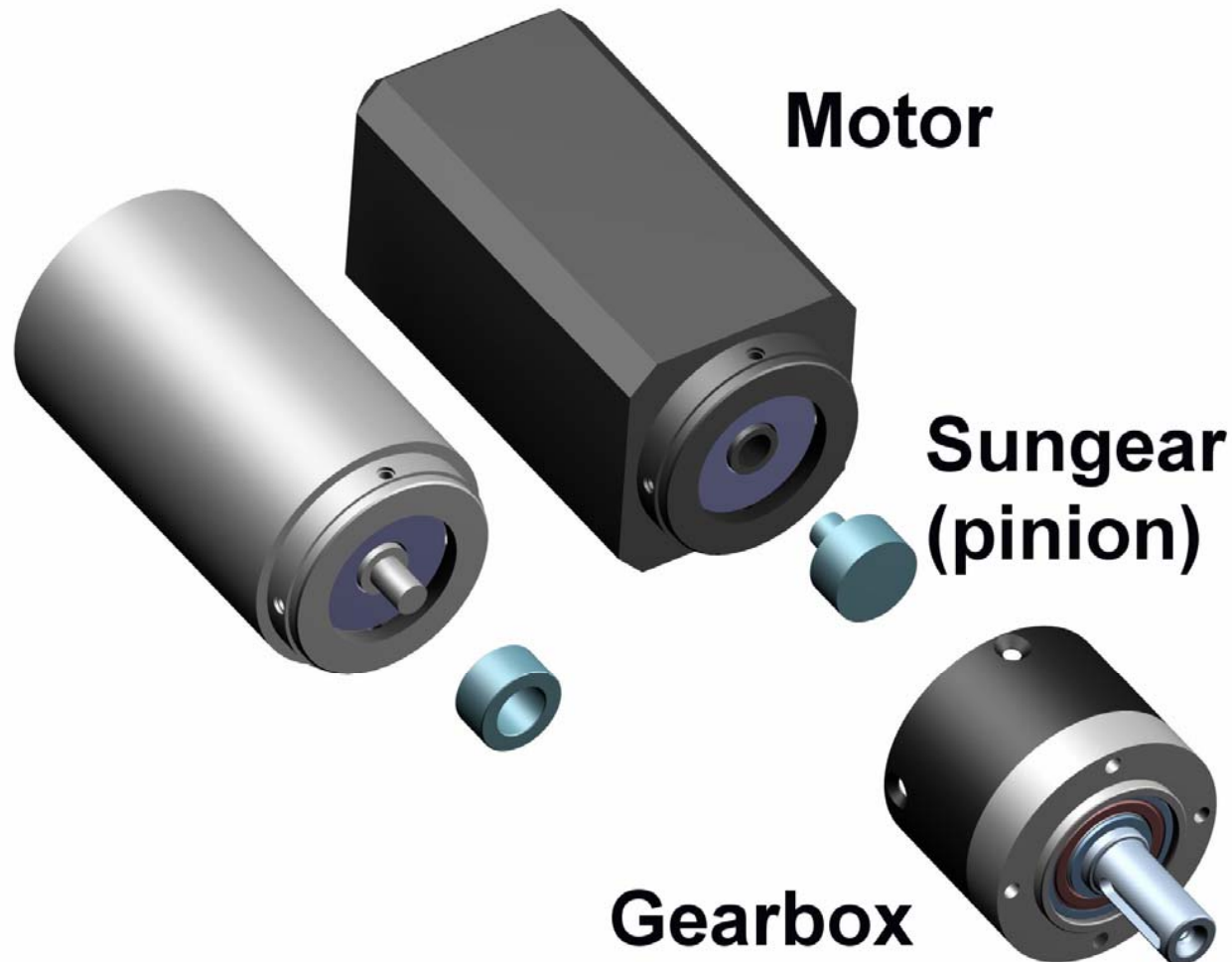

Motor

**Sungear
(pinion)**

Gearbox

Required Motor
Modifications :

Motor Flange
(to match PLE housing)

Motor Shaft with bore
or Stub Shaft (to match the
pinion shaft or bore)

Motor Front Bearing
with Seal (Sealed Bearing)

NEUGART PLE for Direct Motor Attachment DMA

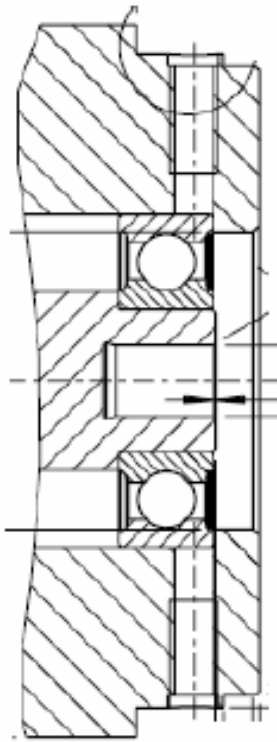

Typical Required Motor Interface

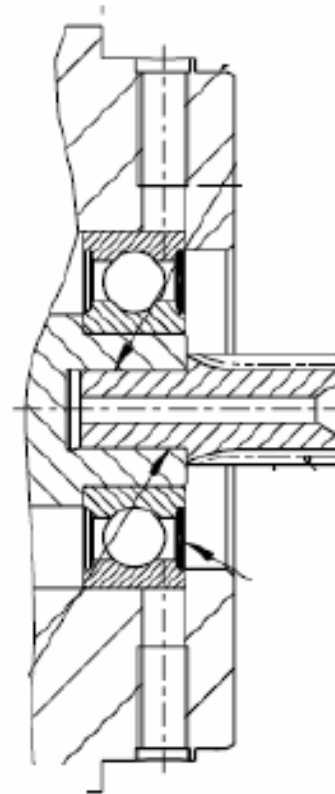

Motor Shaft with fitted Pinion

Example