

The NEUGART “NIECÔ System”

100% Rated Torque at high input speeds and elevated temperatures

Planetary gears are increasingly used in a wide variety of machinery to boost the motor torque, match the load and motor inertia and reduce the high speed of the motor. The inherent advantages of the planetary design, such as high power density, high efficiency,

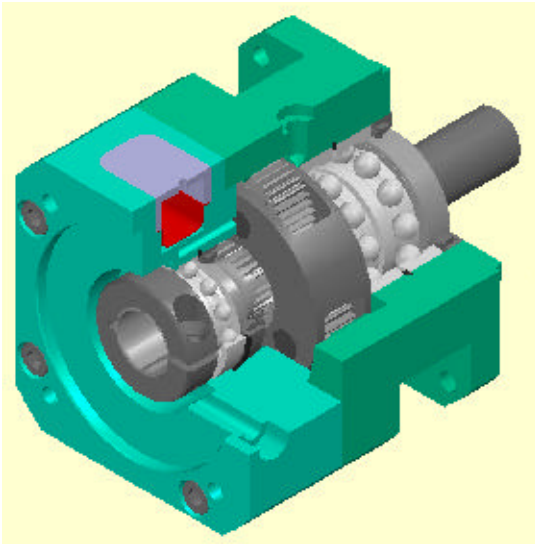

high stiffness, low backlash, and high operational reliability makes it the ideal choice for automation & positioning applications using state servo or stepper motors.

The recently developed servomotors feature high-density rare earth magnets and considerably increased speed. Both measures are significantly increasing the

power density of the servomotor. In the past years, the motor speeds have increased by 1,000 to 2,000 rpm which has elevated the rated (continuous) speed of the new servomotors to 4,000 to 6,000 rpm. Short-term, peak speeds of 800 to 1000 rpm becoming common especially in smaller size motors. As a result the new state of the art servomotors are characterized by compact size, low inertia, high speed and high torque. The higher speeds and lower motor inertia requires gearboxes to reduce the speed and match the inertias as mentioned above. The Planetary Servo-Gearboxes (gearboxes designed primarily to match the servo motors) have to satisfy the increased load and speed.

From the “gearbox point of view” doubling the speed means doubling the load cycles the gears are subjected to and hence the gears must not be loaded above the endurance limit. The friction losses are increasing proportionally with the speed increase, which occurs mainly at the rubbing shaft seals (but also in the bearings and gear mesh). The result is a rise in temperature in the gearbox, this increases the pressure-rise and in turn the seal lips are pressed with a greater force against the rotating shaft. The higher

contact pressure at the seal increases the friction and increases the friction losses, the temperature, the pressure a “vicious circle”, which frequently results in lubricant leakage, seal blow out and in always drastically reduces the seal life, which will again cause premature leakage.

To match the higher input speeds, the majority of planetary servo gearbox manufacturers are introducing speed dependant factors reducing the torque rating of the gearbox. The **NEUGART** approach to this problem is different.

First of all, since the rated torque of the **NEUGART** gearboxes are based on unlimited gear life (rated load is at or below the endurance limit – *the horizontal portion of the “S-N” curve*) the gear strength is not limited by the speed. To reduce / eliminate the above described effects of the high speed on the seals and leakage **NEUGART** introduced the patented **NIECÔ**-system.

As result there is no rated torque & life reduction necessary selecting a **NEUGART PLS Planetary Servo Gearbox with NIECÔ option**.

What is this **NIECÔ** system?

The **NIECÔ** System breaks the vicious circle described above by compensating / eliminating the pressure-rise. This is achieved by integrating an expansion chamber in the gearbox, hence the name “**NEUGART** **I**ntegrated **E**xpansion **C**hamber“. The expansion chamber drastically reduces and many times practically eliminates the pressure build up without allowing the lubricant, the oil mist to exit from the gearbox during the expansion phase, or allow external air, vapor, water or other contaminants to enter the gearbox, which is the happens if using conventional “breathers” or pressure relief valves. The task is to completely seal the gearbox from the ambient air but still allow for pressure compensation.

Conventional gearboxes (fixed axis helical, spur or worm) have generally a large cavity inside the gearbox filled with air, which means, large additional expansion chamber would be needed to effectively reduce the pressure due build up. The compact planetary

servo gearboxes from **NEUGART** have minimal air cavity inside the gearbox. This allows for integrating a chamber within the housing that does not affect the overall gearbox dimensions. The expansion chamber is separated from the gearbox interior cavity by a flexible specially shaped membrane made of temperature resistant elastomer.

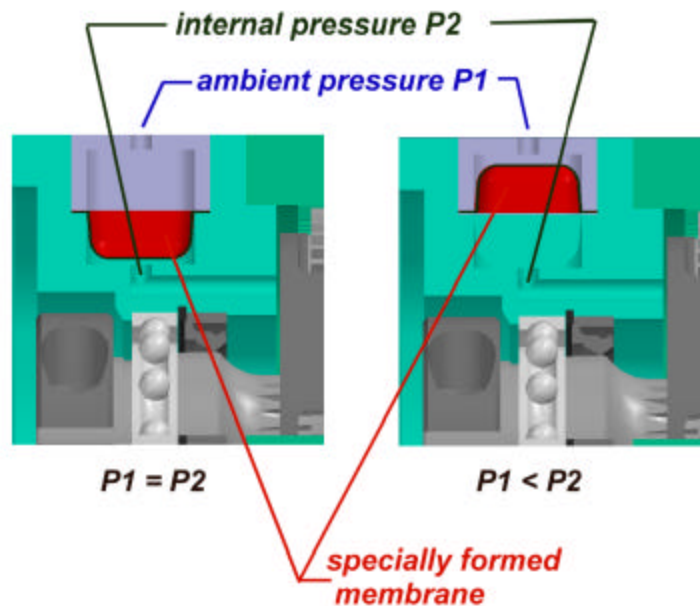

The left side of the figure shows the membrane in “cold condition”, without any internal pressure buildup. The right hand side shows the condition during running, after the temperature rise, the membrane becomes “turned inside out”, increasing the volume and compensating (virtually eliminating) the pressure rise in the gearbox.

Most shaft seal manufacturers recommend a maximum pressure buildup of up to 500mbar to maintain an adequate seal life, avoiding progressive wear of the seal lip and the consequential leakage. With increased speed the recommended maximum over-pressure is further reduced. The graph below shows the effectiveness of the **NIECÔ** system. (The measurements were carried out on a high-speed PLS gearbox)

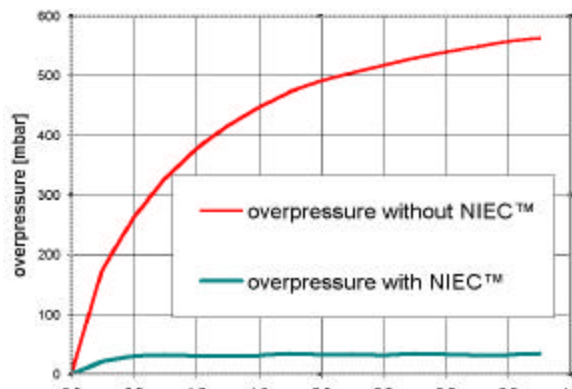

The advantages of the **NIECÔ** System at a glance

- high speeds possible without any gearbox de-rating
- up to 50% lower gearbox temperature
- higher efficiency and thus lower friction at the seal lip
- longer seals life and thus longer intervals between maintenance stops
- no leakage of oil grease through vent-hole, breather or by “blow by effect” at the shaft seal lips
- the internal space of the gear box is completely closed (IP 65)
- no dimensional changes of gear box
- same flush appearance of the gear box is maintained